

Indian Affairs, Division of Facilities  
Management and Construction

# Indian Affairs-Facility Management System (IA-FMS) Training

**S&CAP**

**Abatement Plans and Cost Estimating  
Webinar**

**4/28/2016**

# IA-FMS Overview

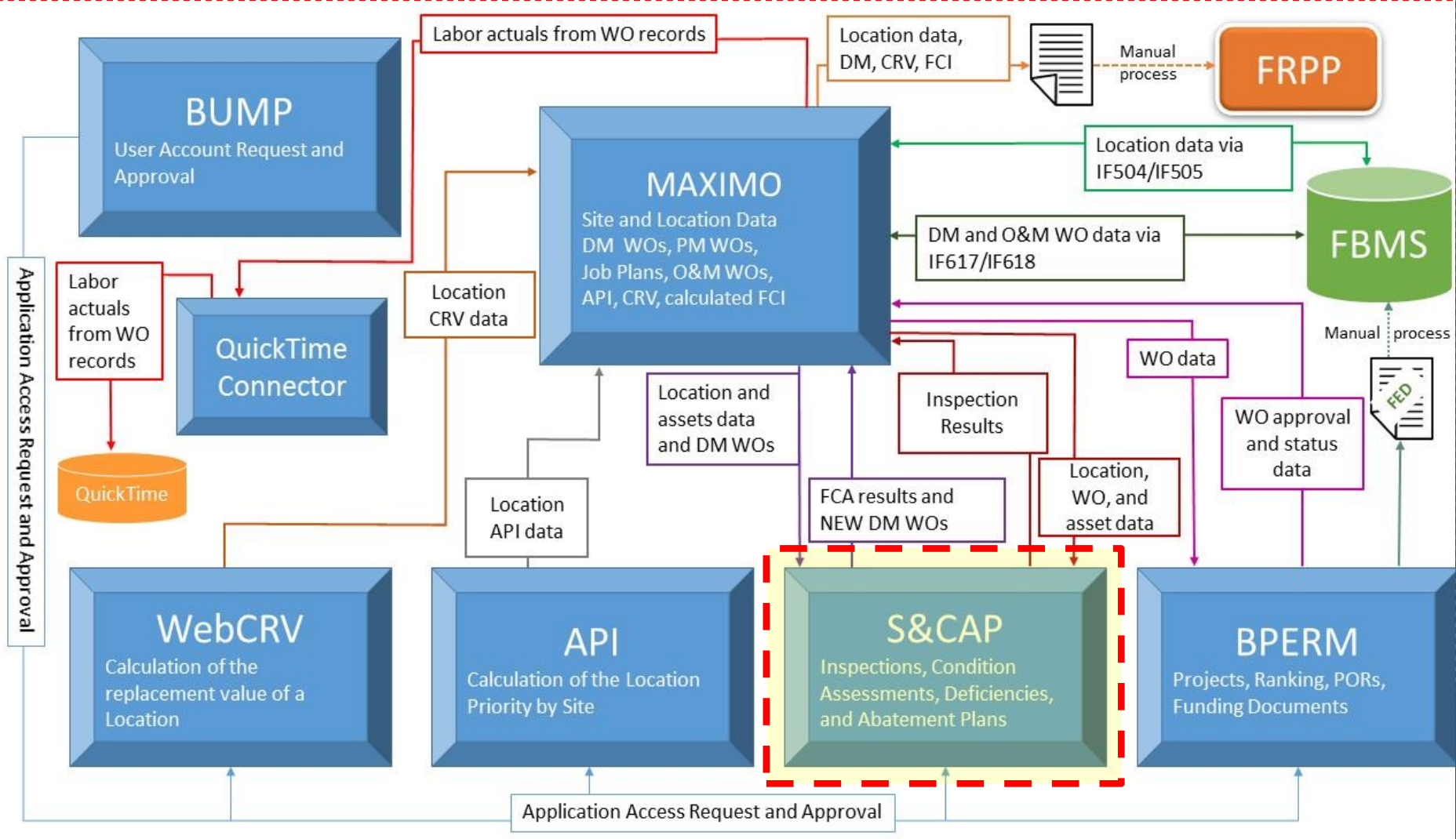

Lesson

**S&CAP**

**Abatement Plans and Cost  
Estimating**

# Lesson goals

- This lesson will cover the following specifics within IA-FMS (S&CAP):
  - Creating Abatement Plans for Safety inspections
  - Adding abatement information to deficiencies
  - Finalizing an Abatement Plan
  - Running the Abatement Correction Plan report
  - Adding a Cost Estimate to a deficiency
  - Sending deficiencies to IA-FMS (Maximo)

# Safety & Other Inspections

- S&CAP stands for Safety & Condition Assessment Portal
- Safety & Other refers to non CA inspections in S&CAP
- Safety & Other Inspection Types:
  - Safety Inspections
    - S (Safety & Health)
    - J (Detention Center Safety and Health)
    - A (Additional Regional Health and Safety)
    - H (Indian Health Services)

# Safety & Other Inspections

- Safety & Other Inspection Types:
  - Other Inspections
    - B (Boiler, Pressure Vessels)
    - F (Fire Department)
    - G (General Facilities)

# IA-FMS DM Overall Process

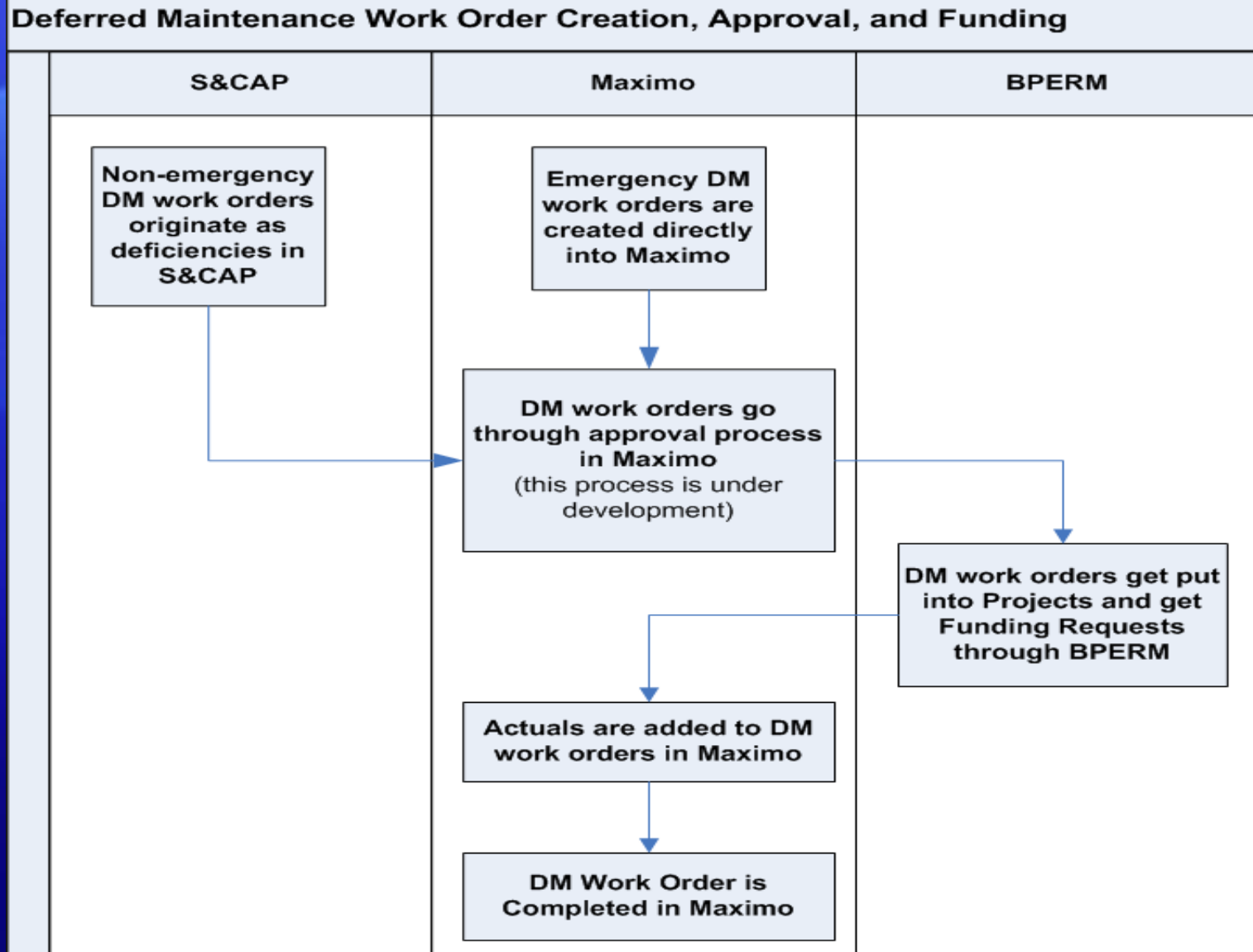

# S&CAP Process Overview

## S&CAP Process Overview

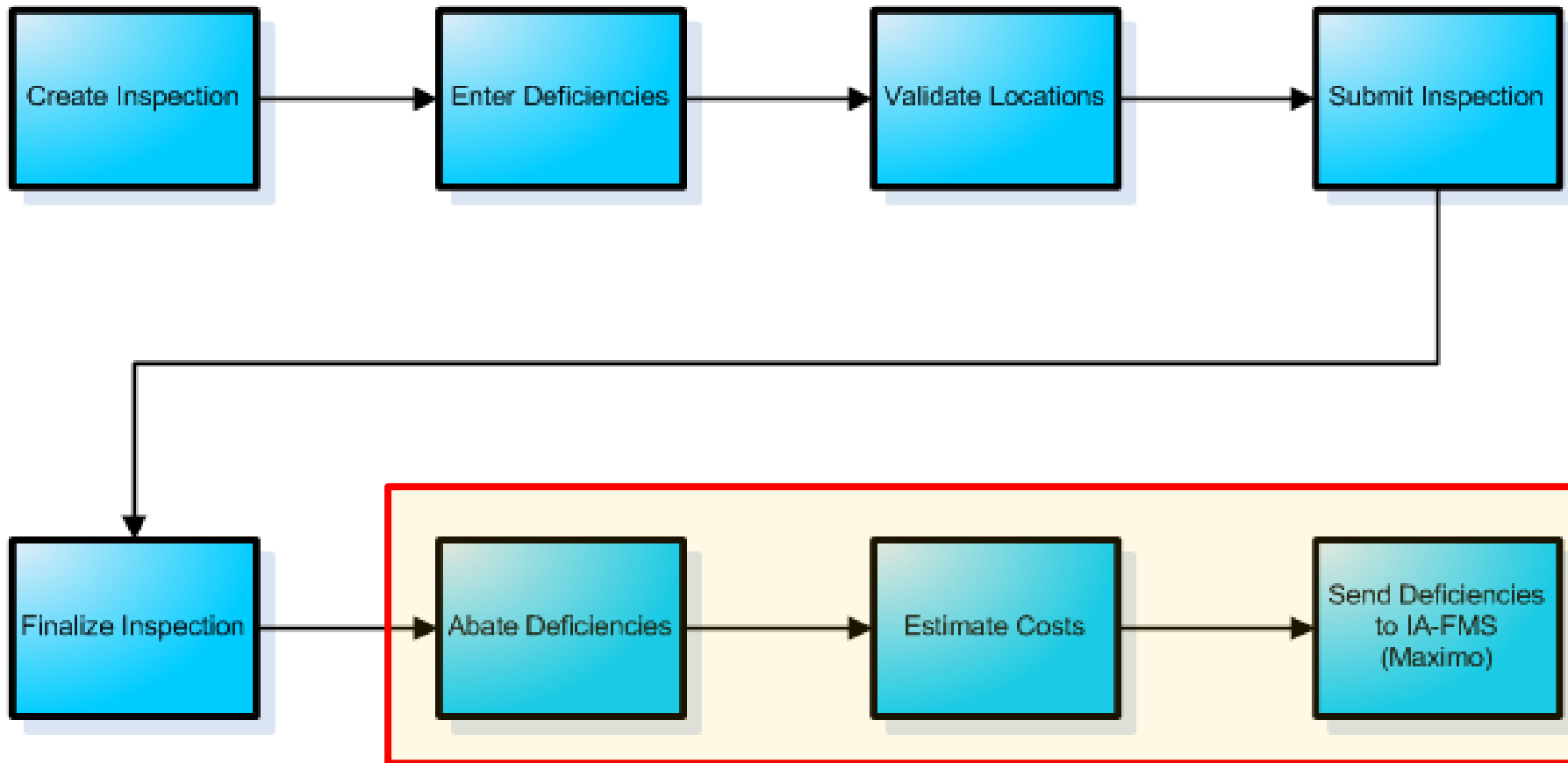



# Changing Roles

- If you have multiple user roles for S&CAP in BUMP, you can easily switch between these roles

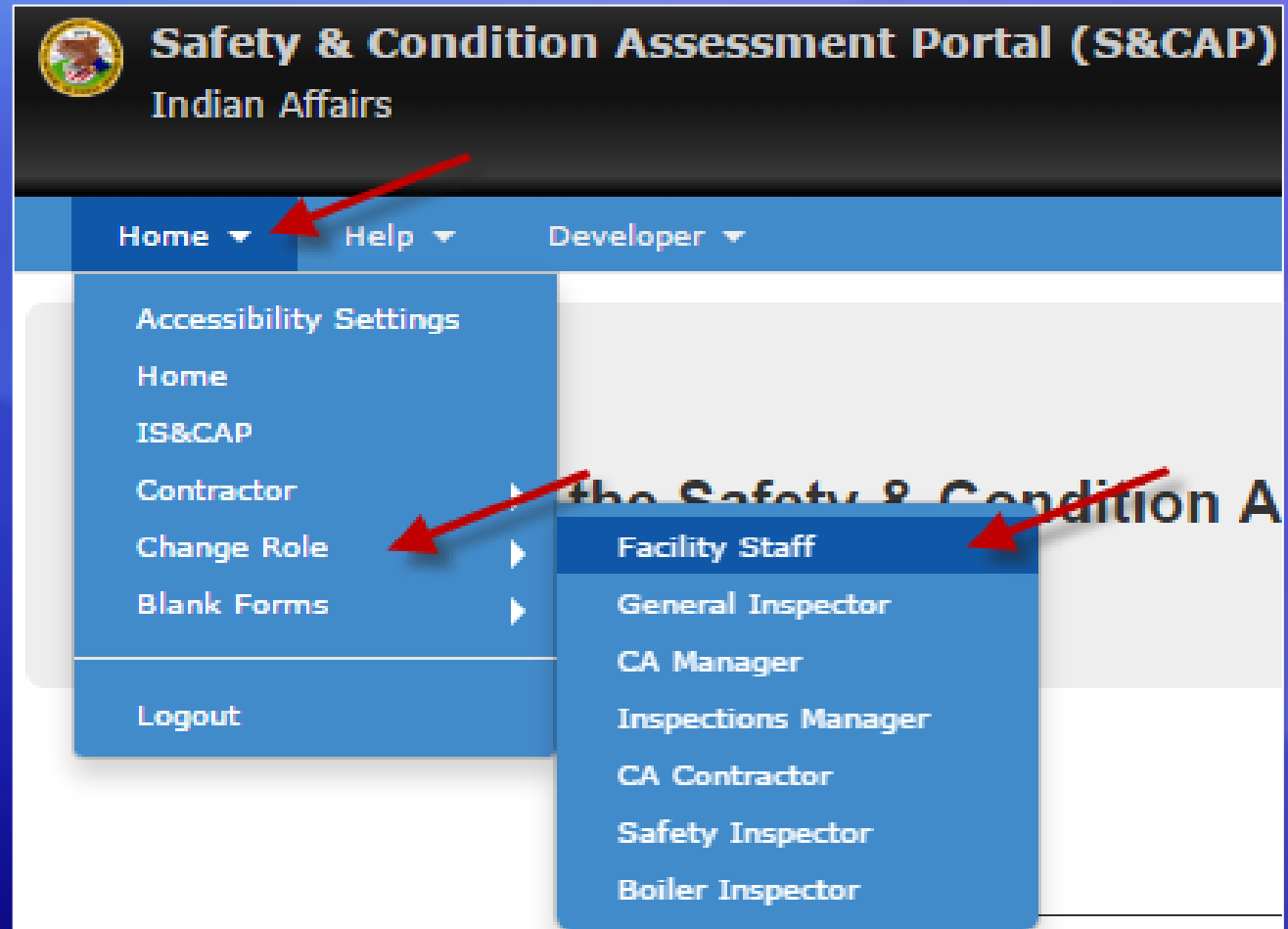





# Abatement Plans

Home ▾ Inspection Data Entry **Abatement Plans** Cost Estimating Reports ▾ Help ▾

Welcome to the Safety & Condition Assessment Portal

Abatement Plans Detail

New Abatement Plan button  **New Abatement Plan**

◀ Previous **1** 2 3 4 Next ▶ 1 - 25 of 78 results (page 1 / 4)   

Inspection Number ▲ 1	Created Date	Created By	Finalized Date	Finalized By
<input type="text"/>	<input type="text"/>	<input type="text"/>	<input type="text"/>	<input type="text"/>
A-2014-2170	12/23/2014	FacilityStaff		
A-2014-2170	12/23/2014	FacilityStaff		
A-2014-2175	09/18/2014	FacilityStaff	09/18/2014	CostEstimator

# Setting Up an Abatement Plans

Abatement Plans		Detail	
<b>Inspection Number*</b>	<input type="text"/>	<b>Inspection Finalized Date</b>	<input type="text"/>
<b>Created Date*</b>	<input type="text" value="03/27/2015"/>	<b>Finalized Date</b>	<input type="text"/>
<b>Created By*</b>	<input type="text" value="Staff, Region"/>	<b>Finalized By</b>	<input type="text"/>
<input type="button" value="Create Abatement Plan"/>			

# Adding Abatement Data to Deficiencies

**Inspection Number\***  **Inspection Finalized Date**

**Created Date\***  **Finalized Date**

**Created By\***  **Finalized By**

**Deficiency** total count: 10

/ Updated Work Order:

Deficiency/Work Order #	Site ID	Structure #	Description	Category	Rank	RAC	Type	SentToCosting
AB152792	IA027	265	CONSTRUCT NEW SINGLE OCCUPANCY RESTROOM IN AN EXISTING OFFICE/ACADEMIC AREA TO ACCOMMODATE ADA	H	1	1	None	No
S-2015-3445_2	IA027	265	Exit is obstructed by hazard	H	2	3	None	No
S-2015-3445_3	IA027	265	Replace handrail	S	2	3	None	No
S-2015-3445_4	IA027	265	Concrete is cracked at building entrance	S	1	4	None	No
S-2015-3445_5	IA027	265	Fire Extinguisher needs to be replaced	S	2	2	None	No
S-2015-3445_6	IA027	265	Handicap deficiency	H	1	5	None	No
S-2015-3445_7	IA027	265	Flexible electric cords are run through doorways, windows, or similar openings.	S	1	1	None	No
S-2015-3445_8	IA027	265	Portable fire extinguishers are discharged and/or missing from designated places.	S	2	3	None	No
S-2015-3445_9	IA027	265	Exit/egress door operation is obstructed by devices	H	2	4	None	No
S-2015-3445_10	IA027	266	Deficiency at BUILDING/SHOP/ROADS	H	2	2	None	No

# Abatement Fields

S-2015-145_74	IE027	226	Exits, means of egress, and/or exit discharge are not maintained free of obstructions or impediment	S	2	5	None	No
S-2015-145_75	IE027	226	Sprinkler riser lacks hydraulic calculation plate.	S	2	5	None	No
S-2015-145_76	IE027	219	Storage obstructs access to the electric control panel.	S	2	5	None	No

## Deficiency Information

<b>Deficiency / Work Order Number</b>	S-2015-145_76	<b>Description</b>	Storage obstructs access to the electric control panel.
<b>Category</b>	S	<b>Rank</b>	2
<b>Structure #</b>	219	<b>RAC</b>	5
<b>Site ID</b>	IE027	<b>Site Description</b>	CHOCTAW CENTRAL SCHOOL
<b>Maximo ID</b>	AB105704	<b>Location Description</b>	School, Secondary, Day
<b>Inspection Number</b>	S-2015-145	<b>Inspection Finalized Date</b>	09/18/2015

**Additional Information** Storage obstructs access to the electric control panel.

## Abatement

**Deficiency Type\***

**Planned Corrective Measure\***



**Planned Completion Date\***

**Revised Completion Date**

**Estimated Completion Date**

**Abated Date**

**Abated By**

Previous

Save

Send to Costing

Next

# Interim Measures

Abatement

**Deficiency Type\***

**Planned Corrective Measure\***

**Planned Completion Date\***

**Revised Completion Date**

**Estimated Completion Date**

**Abated Date** **Abated By**

Interim Measure

This deficiency requires an Interim Measure since the Planned Completion date is 30 days after the Inspection was finalized. Please create an Interim Measure.

**Reason For Delay\***

**Interim Measure Description\***

**Planned Funding Method**

**Planned Completion Date\***

**Created Date\*** **Created By\***

# Finalizing Abatement

Abatement Plans **Detail**

<b>Inspection Number*</b>	S-2015-3445	<b>Inspection Finalized Date</b>	03/26/2015
<b>Created Date*</b>	03/27/2015	<b>Finalized Date</b>	
<b>Created By*</b>	Staff, Region	<b>Finalized By</b>	

**Finalize Plan** ← Finalize Plan button

# Cost Estimating

## Welcome to the Safety & Condition Assessment Portal

Deficiencies / Work Orders to be Costed Detail Bundle DM Work Orders

CURRENT FILTERS ▶ Inspection Number: S-2015-3445

◀ Previous Next ▶ 1 - 10 of 10 results (page 1 / 1)



Funding Type ▲	Deficiency / Work Order Number	Deficiency / Work Order Description	Inspection Number	Inspection Finalized Date	Cost Estimate Total	Site ID	Site Description	Maximo ID	Location Description
			S-2015-3445						
AB152792		CONSTRUCT NEW SINGLE OCCUPANCY RESTROOM IN AN EXISTING	S-2015-3445	03/26/2015	\$0.00	IA027	MAKAH AGENCY	AB105560	BUILDING / OFFICE
S-2015-3445_2		Exit is obstructed by hazard	S-2015-3445	03/26/2015	\$0.00	IA027	MAKAH AGENCY	AB105560	BUILDING / OFFICE
S-2015-3445_3		Replace handrail	S-2015-3445	03/26/2015	\$0.00	IA027	MAKAH AGENCY	AB105560	BUILDING / OFFICE
S-2015-3445_4		Concrete is cracked at building entrance	S-2015-3445	03/26/2015	\$0.00	IA027	MAKAH AGENCY	AB105560	BUILDING / OFFICE



# Adding Costs

Apply Geographic Factor?

Planned Funding Method: O&M

Funding Type: O&M

Standing Parent: STRUCTURE 265 FO SO

**Finalize Cost**

Line Items:

Estimate Type	Item Description	Unit of Measure	Material Cost	Labor Hours	Labor Cost	Equipment & Tools Hours	Equipment & Tools Cost	Total Cost	Overhead & Profit %	Total including Overhead & Profit %	Cost Estimate Total	Delete
---------------	------------------	-----------------	---------------	-------------	------------	-------------------------	------------------------	------------	---------------------	-------------------------------------	---------------------	--------

**Add Line Item** ← Add Line Item button

Unit Cost Totals	
Material Cost	\$0.00
Labor Cost	\$0.00
Equipment Cost	\$0.00

Square Foot Totals	
Quarter	\$0.00
Median	\$0.00
Three Quarter	\$0.00

Assembly Cost Totals	
Assembly Material Cost	\$0.00
Assembly Installation Cost	\$0.00

Grand Totals	
Overhead & Profit	\$0.00
Grand Total	\$0.00

# Selecting Estimate Type

Line Items:

Estimate Type	Item Description	Quantity	Unit of Measure	Material Cost	Labor Hours	Labor Cost	Equipment & Tools Hours	Equipment & Tools Cost	Total Cost	Overhead & Profit %	Total including Overhead & Profit %	Cost Estimate Total	Delete
---------------	------------------	----------	-----------------	---------------	-------------	------------	-------------------------	------------------------	------------	---------------------	-------------------------------------	---------------------	--------

[Add Line Item](#)

IA Single/Detailed Cost Estimate

Cost Estimated Date: 03/30/2015

Cost Estimator's Name: Sean Bolling

Estimate Type\*: IA Single Cost Estimate

Item Description\*: IA Single Cost Estimate

Bare Cost\*: IA Detailed Cost Estimate  
RS Means Books Assembly Cost Estimate  
RS Means Books Square Foot Estimate  
RS Means Books Unit Cost Estimate

Material Quantity:

Material Unit of Measure:

Material Cost:

Labor Hours:

# Cost Estimate Fields

Estimate Type	Fields
IA Single Cost Estimate	<ul style="list-style-type: none"> <li>○ Item Description*</li> <li>○ Bare Cost*</li> <li>○ Overhead &amp; Profit %</li> </ul>
IA Detailed Cost Estimate	<ul style="list-style-type: none"> <li>○ Item Description*</li> <li>○ Material Quantity*</li> <li>○ Material Unit of Measure*</li> <li>○ Material Cost*</li> <li>○ Labor Hours*</li> <li>○ Labor Cost*</li> <li>○ Equipment/Tool Hours*</li> <li>○ Equipment/Tools Cost*</li> <li>○ Overhead &amp; Profit %</li> </ul>
RS Means Books Assembly Cost Estimate	<ul style="list-style-type: none"> <li>○ Item Description*</li> <li>○ Overhead &amp; Profit %</li> <li>○ Assembly Material Cost*</li> <li>○ Assembly Installation Cost*</li> </ul>
RS Means Books Square Foot Estimate	<ul style="list-style-type: none"> <li>○ Item Description*</li> <li>○ Overhead &amp; Profit %</li> <li>○ Quarter*</li> <li>○ Median*</li> <li>○ Three Quarter*</li> </ul>
RS Means Books Unit Cost Estimate	<ul style="list-style-type: none"> <li>○ Item Description*</li> <li>○ Overhead &amp; Profit %</li> <li>○ Material Cost*</li> <li>○ Labor Cost*</li> <li>○ Equipment/Tool Cost*</li> </ul>

# Save or Delete Costing Items

Line Items:

Estimate Type	Item Description	Quantity	Unit of Measure	Material Cost	Labor Hours	Labor Cost	Equipment & Tools Hours	Equipment & Tools Cost	Total Cost	Overhead & Profit %	Total including Overhead & Profit %	Cost Estimate Total	Delete
Detailed	handrail replacement	1	LF	\$55.00	28	\$15.00	16	\$50.00	\$1,275.00	0%	\$1,275.00	\$1,275.00	X

[Add Line Item](#)

Delete Line Item 

# Deficiencies Costed as O&M

Apply Geographic Factor?

Planned Funding Method: O&M

Funding Type: O&M

Standing Parent: STRUCTURE 265 FO SO

**Select Standing Parent**

- STRUCTURE 265 FO SO (AB106452)
- STRUCTURE 265 GM SO (AB106456)
- STRUCTURE 265 PM SO (AB106454)
- STRUCTURE 265 PS SO (AB106453)
- STRUCTURE 265 UM SO (AB106455)
- No Standing Parent

**Finalize Cost**

**Finalize Cost button**

Line Items:

Estimate Type	Item Description	Quantity	Unit of Measure	Material Cost	Labor Hours	Labor Cost	Equipment & Tools Hours	Equipment & Tools Cost	Total Cost	Overhead & Profit %	Total including Overhead & Profit %	Cost Estimate Total	Delete
Detailed	handrail replacement	1	LF	\$55.00	28	\$15.00	16	\$50.00	\$1,275.00	0%	\$1,275.00	\$1,275.00	X

# Deficiencies Costed as DM

Apply Geographic Factor?

Planned Funding Method

Funding Type

Line Items:

Estimate Type	Item Description	Quantity	Unit of Measure	Material Cost	Labor Hours	Labor Cost	Equipment & Tools Hours	Equipment & Tools Cost	Total Cost	Overhead & Profit %	Total including Overhead & Profit %	Cost Estimate Total	Delete
Detailed	replace concrete	500	SF	\$10.00	40	\$12.00	40	\$15.00	\$6,080.00	0%	\$6,080.00	\$6,080.00	X

Apply Geographic Factor?

Planned Funding Method

Funding Type

# Bundling DM Deficiencies

Deficiencies / Work Orders to be Costed    Detail    **Bundle DM Work Orders**

← Previous    1    2    3    4    Loading ...    1 - 25 of 95 results (page 1 / 4)

*Bundle DM Work Orders tab*

Deficiencies / Work Orders to be Costed    Detail    **Bundle DM Work Orders**

Bundle Total    2501.00    **Send Bundle to IAFMS**

CURRENT FILTERS ▶ Inspection Number: S-2015-3445

← Previous    Next ▶    1 - 4 of 4 results (page 1 / 1)

*Send Bundle to IAFMS button*

Funding Type	Deficiency / Work Order Number	Deficiency / Work Order Description	Inspection Number	Inspection Finalized Date	Cost Estimate Total	Site ID	Site Description	Maximo ID	Location Description	Category	Rank	Parent Work Order
DM	S-2015-3445_2	Fix exit light 1	S-2015-3445	03/26/2015	\$751.00	IA027	MAKAH AGENCY	AB105560	BUILDING / OFFICE	H	2	
DM	S-2015-3445_4	Concrete is cracked at building entrance	S-2015-3445	03/26/2015	\$6,080.00	IA027	MAKAH AGENCY	AB105560	BUILDING / OFFICE	S	1	
DM	S-2015-3445_9	Fix exit light 2	S-2015-3445	03/26/2015	\$1,750.00	IA027	MAKAH AGENCY	AB105560	BUILDING / OFFICE	H	2	
DM	S-2015-3445_10	Replace exit door at BUILDING/SHOP/ROADS	S-2015-3445	03/26/2015	\$1,200.00	IA027	MAKAH AGENCY	AB105561	BUILDING / SHOP / ROADS	H	2	

# Confirmation of Bundling

Do you want to create a bundle? Bundles should include similar items.

**Bundle Description\***

Yes

No



# Sending Repeat Deficiencies to IA-FMS

Apply Geographic Factor?

Planned Funding Method: O&M Funding Type: O&M

Standing Parent: STRUCTURE 265 FO SO

**Finalize Cost** Finalize Cost button

Line Items:

Estimate Type	Item Description	Quantity	Unit of Measure	Material Cost	Labor Hours	Labor Cost	Equipment & Tools Hours	Equipment & Tools Cost	Total Cost	Overhead & Profit %	Total including Overhead & Profit %	Cost Estimate Total	Delete
---------------	------------------	----------	-----------------	---------------	-------------	------------	-------------------------	------------------------	------------	---------------------	-------------------------------------	---------------------	--------

Warning ×

Would you like to send the deficiency to IAFMS without changing the costing?

# Demonstration

## S&CAP Abatement Plans and Cost Estimating

This webinar presentation is available to download at:  
<http://www.bie.edu/Resources/webinar/index.htm>